



HEAVY DUTY DEEP CYCLE SERIES 5000

BATTERY TYPE	VOLTS	12	12 CS 11P
DIMENSIONS			
LENGTH	559 MM	22	INCHES
WIDTH	286 MM	11 1/4	INCHES
HEIGHT	464 MM	18 1/4	INCHES
WEIGHT DRY	100 KG	220	LBS.
WEIGHT WET	124 KG	272	LBS.
CONTAINER CONSTRUCTION			
INNER CONTAINER	POLYPROPYLENE		
INNER COVER	POLYPROPYLENE - HEAT SEALED TO INNER CONTAINER		
OUTER CONTAINER	HIGH DENSITY POLYETHYLENE		
OUTER COVER	HIGH DENSITY POLYETHYLENE SNAP FIT TO CONTAINER		
HANDLES	MOLDED		
PLATES PER CELL	11		
ELECTROLYTE RESERVE	ABOVE PLATES	95 MM	3.75 INCHES
DESIGN CRITERIA	10 YEAR WARRANTY	3300 CYCLES	15 YEAR LIFE
POSITIVE PLATE DIMENSION			
HEIGHT	273 MM	10.750	INCHES
WIDTH	143 MM	5.625	INCHES
THICKNESS	6.73 MM	0.265	INCHES
NEGATIVE PLATE DIMENSION			
HEIGHT	273 MM	10.750	INCHES
WIDTH	143 MM	5.625	INCHES
THICKNESS	4.70 MM	0.185	INCHES
SEPARATOR	SEPARATOR THICKNESS	0.105 INCH	
INSULATION	POSITIVE PLATE ENVELOPED BY VERTICAL SLYVER GLASS MAT		
TERMINALS	FLAG WITH STAINLESS STEEL NUTS AND BOLTS		
COLD CRANK	CCA	0°F / -17.8°C	845
	MCA	32°F / 0°C	1056
	RESERVE		677
	MINUTES AT 25A		
CAPACITY	20 HR RATE	357	
		CAP / AH	CURRENT / AMPS
CAPACITY AT THE 20 HOUR RATE	1.265 SP. GR.	357	17.9
CAPACITY AT THE 15 HOUR RATE	1.265 SP. GR.	336	22.4
CAPACITY AT THE 12 HOUR RATE	1.265 SP. GR.	318	26.5
CAPACITY AT THE 10 HOUR RATE	1.265 SP. GR.	303	30.3
CAPACITY AT THE 8 HOUR RATE	1.265 SP. GR.	286	35.7
CAPACITY AT THE 6 HOUR RATE	1.265 SP. GR.	264	44.0
CAPACITY AT THE 5 HOUR RATE	1.265 SP. GR.	250	50
CAPACITY AT THE 4 HOUR RATE	1.265 SP. GR.	232	58
CAPACITY AT THE 3 HOUR RATE	1.265 SP. GR.	211	70
CAPACITY AT THE 2 HOUR RATE	1.265 SP. GR.	182	91
CAPACITY AT THE 1 HOUR RATE	1.265 SP. GR.	129	129

PART NUMBER: 12-CS-11P

WEIGHT WET: 272 LB/ 124 KG

WEIGHT DRY: 220 LB/ 100 KG

CAPACITY: 357 AH 20 HR
503 AH 100 HR

VOLTAGE: 12 V

OVERALL DIMENSIONS: 22X 11 1/4X 18 1/4"

 MAX HEIGHT WITH OPTIONAL HYDROCAPS: 18.63"/ 473MM

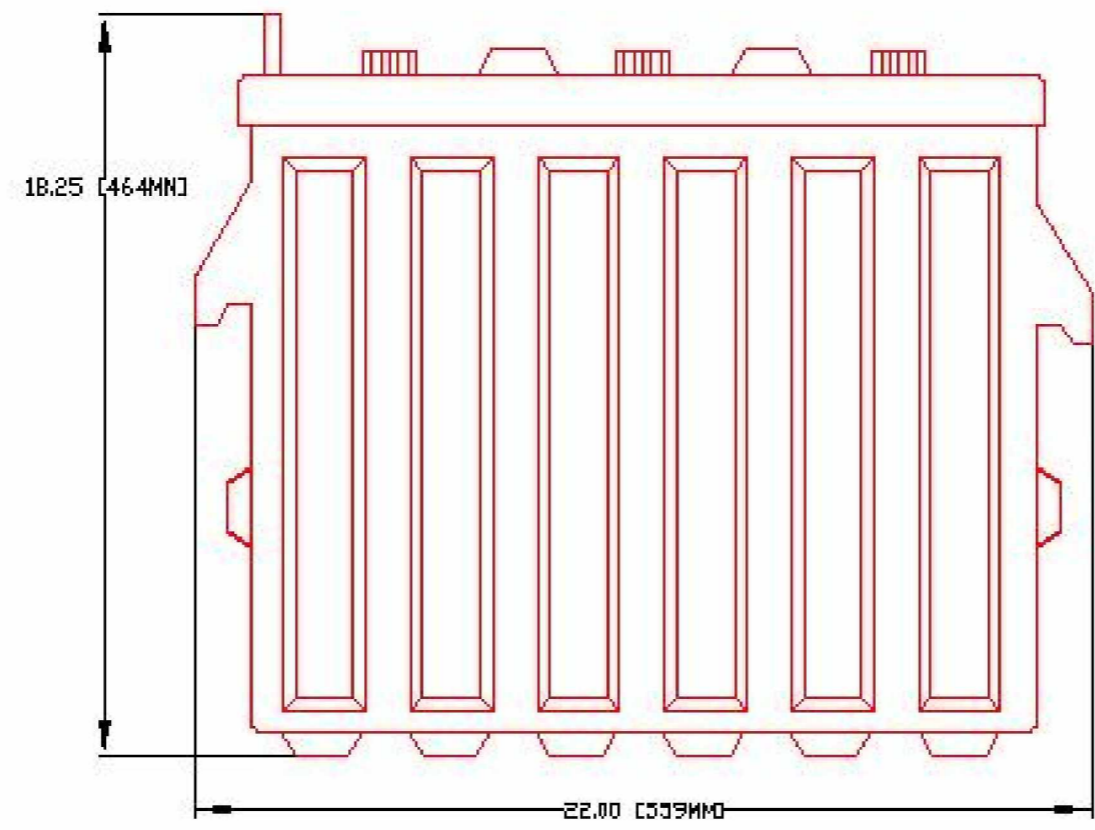
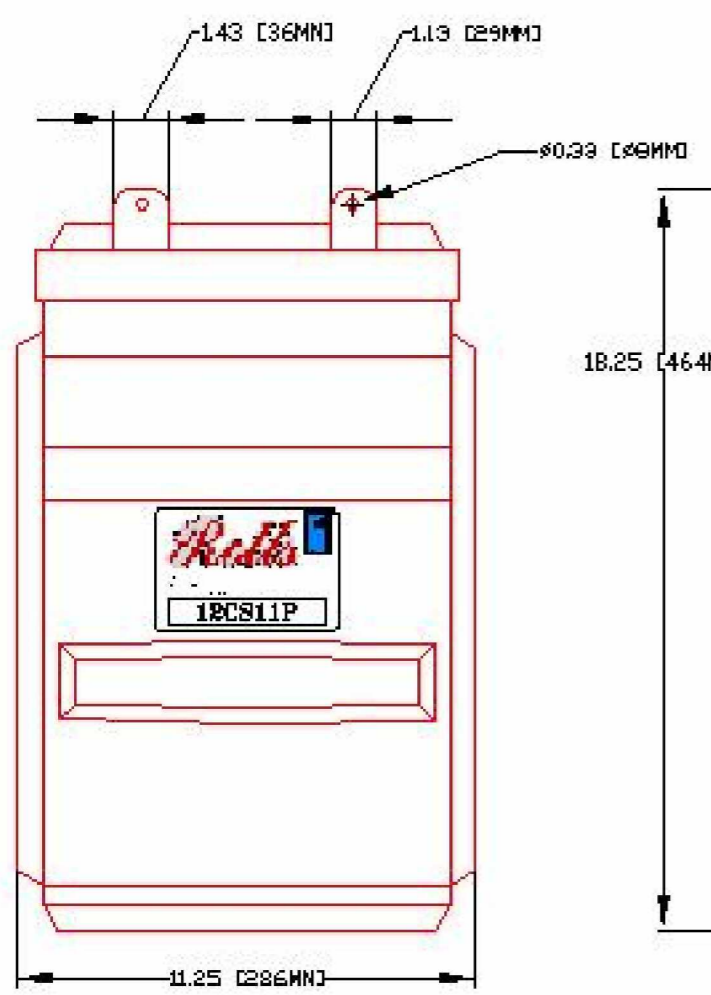
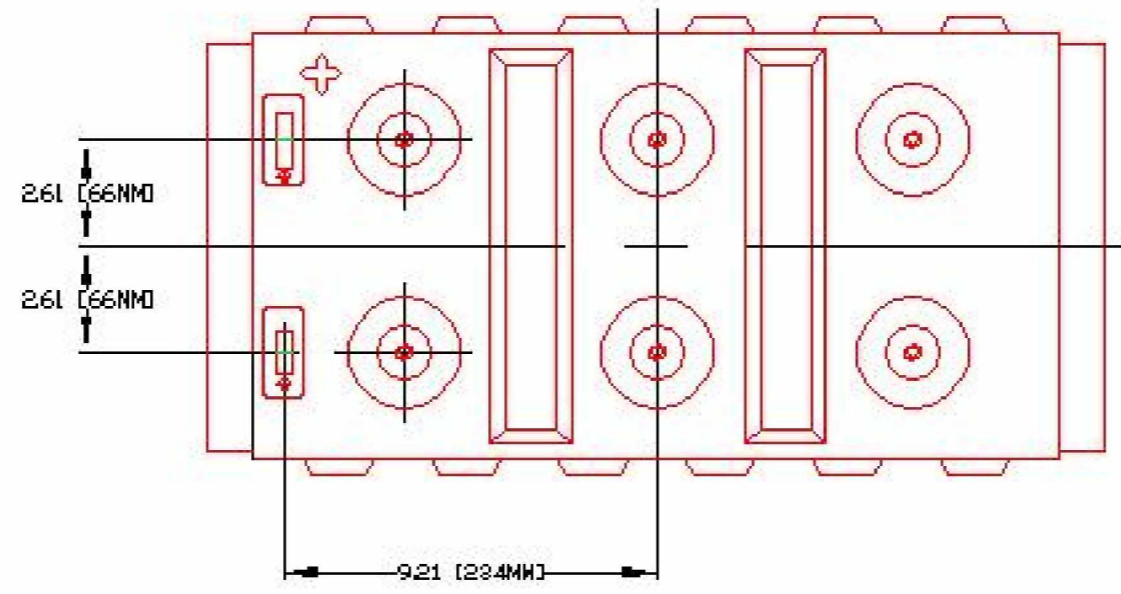

TITLE: 12CS11P

DESCRIPTION: 12V / 6 CELL 11 PLATE (CS) DEEP CYCLE 500/5000 SERIES

CONTACT INFO:
WEB: WWW.ROLLSBATTERY.COM
E-MAIL: SALES@ROLLSBATTERY.COM
PHONE: 1-800-681-9914

SCALE: 1" = 6" 1" = 4" JPEG NOT TO SCALE
8.5" X 11" 11" X 17"

Drawn by: S. WILES Approved By: D. SURRETTE

DATE: 16-Feb-01 REVISION: 1.1

DRAWING NO.: DWG 018, BD12CS11P