



# HEAVY DUTY DEEP CYCLE SERIES 5000

<b>BATTERY TYPE</b>	<b>VOLTS</b>	<b>6</b>		<b>6 CS 17P</b>
<b>DIMENSIONS</b>				
LENGTH			559 MM	22 INCHES
WIDTH			210 MM	8 1/4 INCHES
HEIGHT			464 MM	18 1/4 INCHES
<b>WEIGHT DRY</b>			81 KG	178 LBS.
<b>WEIGHT WET</b>			100 KG	221 LBS.
<b>CONTAINER CONSTRUCTION</b>				
INNER CONTAINER			POLYPROPYLENE	
INNER COVER			POLYPROPYLENE - HEAT SEALED TO INNER CONTAINER	
OUTER CONTAINER			HIGH DENSITY POLYETHYLENE	
OUTER COVER			HIGH DENSITY POLYETHYLENE SNAP FIT TO OUTER CONTAINER	
HANDLES			MOLDED	
<b>PLATES PER CELL</b>			17	
<b>ELECTROLYTE RESERVE</b>	ABOVE PLATES		95 MM	3.75 INCHES
<b>DESIGN CRITERIA</b>	10 YEAR WARRANTY		3300 CYCLES	15 YEAR LIFE
<b>POSITIVE PLATE DIMENSION</b>				
HEIGHT			273 MM	10.750 INCHES
WIDTH			143 MM	5.625 INCHES
THICKNESS			6.73 MM	0.265 INCHES
<b>NEGATIVE PLATE DIMENSION</b>				
HEIGHT			273 MM	10.750 INCHES
WIDTH			143 MM	5.625 INCHES
THICKNESS			4.70 MM	0.185 INCHES
<b>SEPARATOR</b>	SEPARATOR THICKNESS		0.105 INCH	
<b>INSULATION</b>	POSITIVE PLATE ENVELOPED BY VERTICAL SLYVER GLASS MAT			
<b>TERMINALS</b>	FLAG WITH STAINLESS STEEL NUTS AND BOLTS			
<b>COLD CRANK</b>	CCA	0°F / -17.8°C	1357	<b>RESERVE</b>
	MCA	32°F / 0°C	1696	<b>MINUTES AT 25A</b>
				1083
<b>CAPACITY</b>	20 HR RATE		546	
			CAP / AH	CURRENT / AMPS
<b>CAPACITY AT THE 20 HOUR RATE</b>			<b>546</b>	<b>27.3</b>
CAPACITY AT THE 15 HOUR RATE			513	34.2
CAPACITY AT THE 12 HOUR RATE			486	40.5
CAPACITY AT THE 10 HOUR RATE			464	46.4
CAPACITY AT THE 8 HOUR RATE			437	54.6
CAPACITY AT THE 6 HOUR RATE			404	67.3
CAPACITY AT THE 5 HOUR RATE			382	76
CAPACITY AT THE 4 HOUR RATE			355	89
CAPACITY AT THE 3 HOUR RATE			322	107
CAPACITY AT THE 2 HOUR RATE			278	139
CAPACITY AT THE 1 HOUR RATE			197	197



PART NUMBER: 6-CS-17P  
 WEIGHT WET: 221 LB / 100 KG  
 WEIGHT DRY: 178 LB / 81 KG  
 CAPACITY: 546 AH 20 HR  
 770 AH 100 HR  
 VOLTAGE: 6 V  
 OVERALL DIMENSIONS: 22X8 1/4X18 1/4"  
 MAX HEIGHT WITH OPTIONAL HYDROCAPS: 18 5/8" - 473 MM

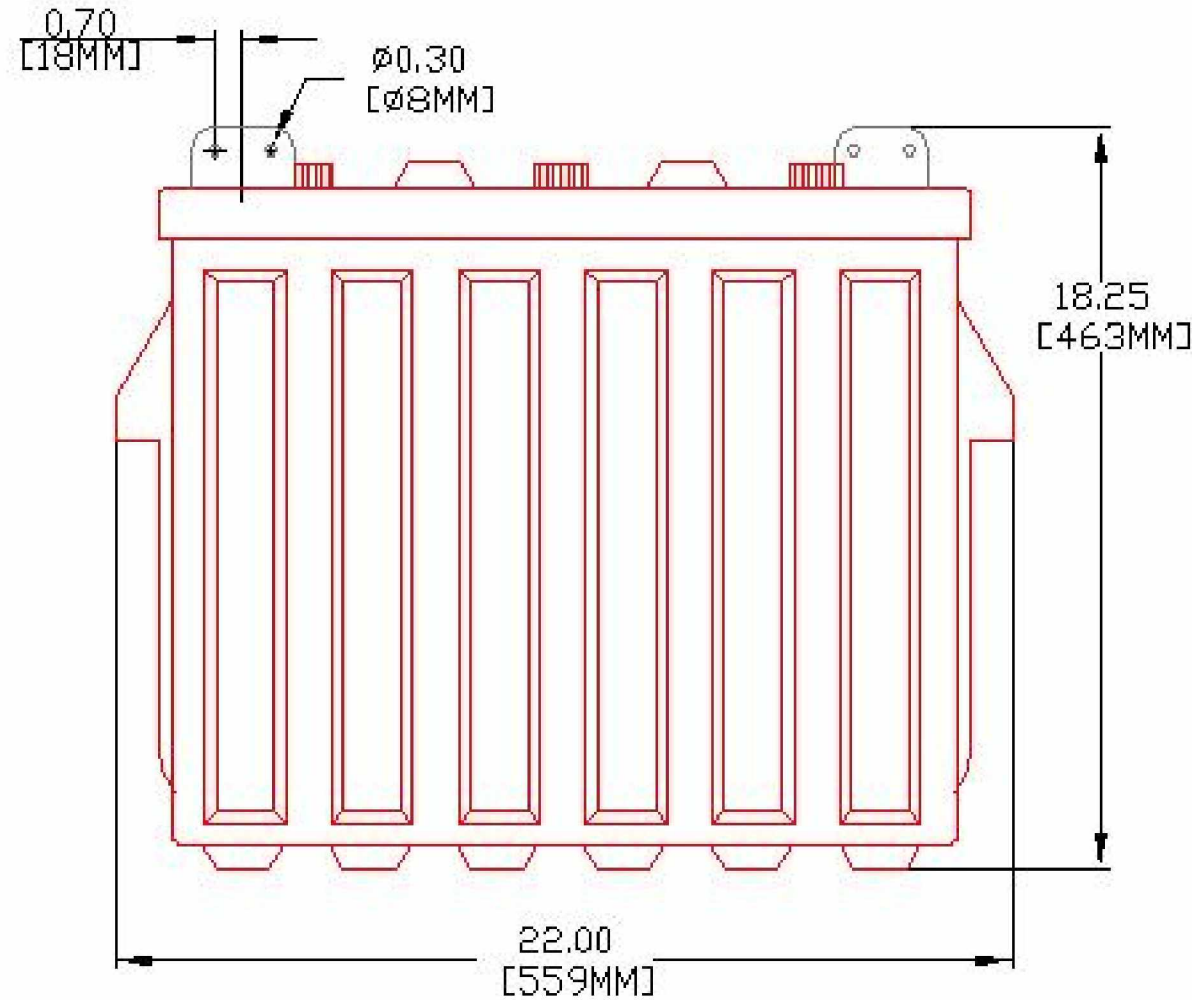
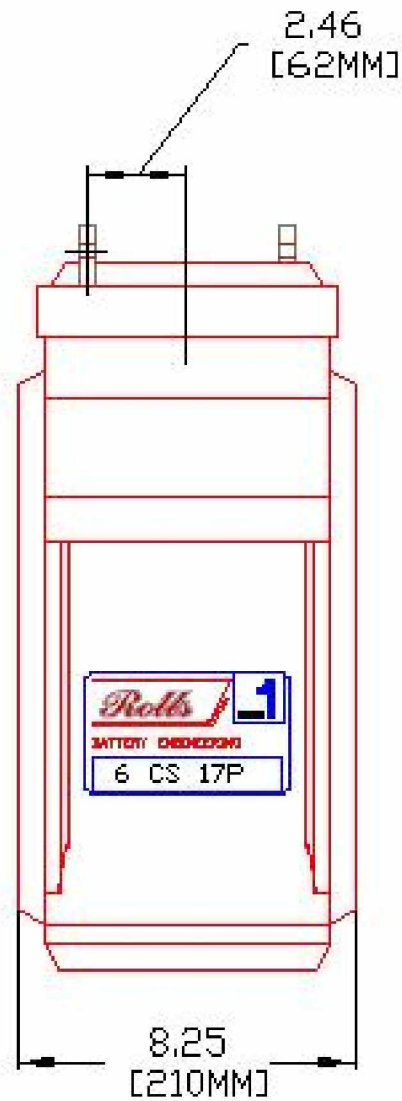
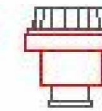
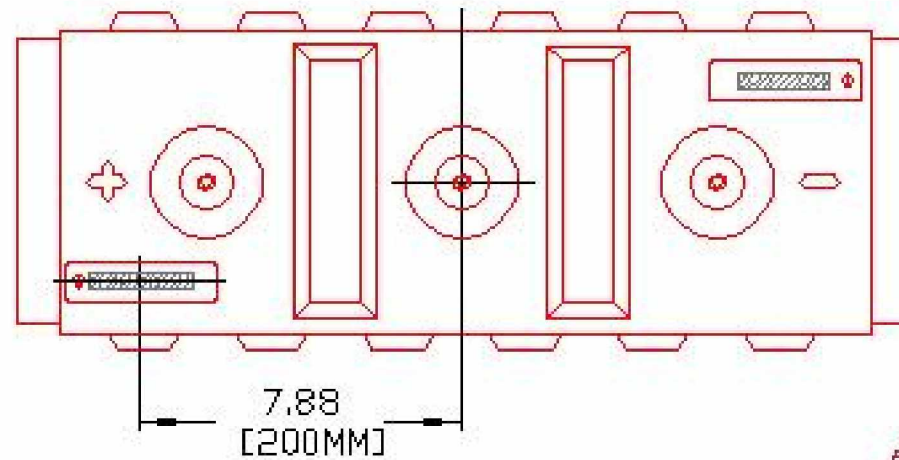

*Rolls*

BATTERY ENGINEERING SALEM, MASS

TITLE: 6CS17P

DESCRIPTION: 6V / 3 CELL 17 PLATE (CS) DEEP CYCLE 500/5000 SERIES

CONTACT INFO:  
 WEB: WWW.ROLLSBATTERY.COM  
 E-MAIL: SALES@ROLLSBATTERY.COM  
 PHONE: 1-800-681-9914

SCALE: 1" = 6" 1" = 4" JPEG  
 8 5/8" X 11" 11" X 17" NOT TO SCALE

Drawn by: S. WILES Approved By: D. SURRETTE

DATE: 14-JUN-00 REVISION 2.1

DRAWING NO: DWG 005, BD6CS17P