

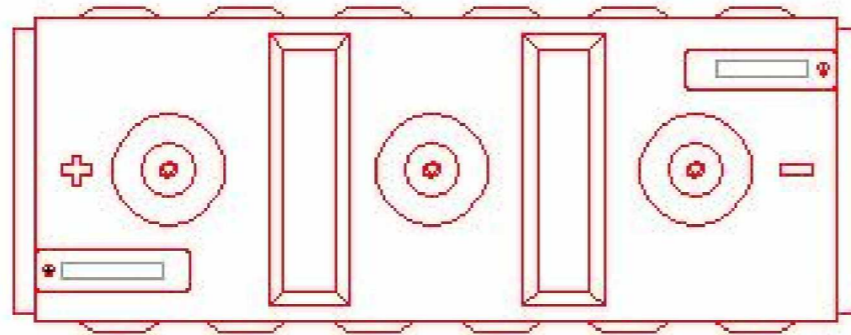



HEAVY DUTY DEEP CYCLE SERIES 4000

BATTERY TYPE	VOLTS	6	6 EHG 31P
DIMENSIONS			
LENGTH			527 MM 20 3/4 INCHES
WIDTH			203 MM 8 INCHES
HEIGHT			324 MM 12 3/4 INCHES
WEIGHT DRY			47 KG 104 LBS.
WEIGHT WET			60 KG 133 LBS.
CONTAINER CONSTRUCTION			
INNER CONTAINER			POLYPROPYLENE
INNER COVER			POLYPROPYLENE - HEAT SEALED TO INNER CONTAINER
OUTER CONTAINER			HIGH DENSITY POLYETHYLENE
OUTER COVER			HIGH DENSITY POLYETHYLENE SNAP FIT TO OUTER CONTAINER
HANDLES			MOLDED
PLATES PER CELL			31
ELECTROLYTE RESERVE	ABOVE PLATES		44 MM 1.75 INCHES
DESIGN CRITERIA	7 YEAR WARRANTY	1300 CYCLES	10 YEAR LIFE
POSITIVE PLATE DIMENSION			
HEIGHT			162 MM 6.375 INCHES
WIDTH			143 MM 5.625 INCHES
THICKNESS			3.81 MM 0.150 INCHES
NEGATIVE PLATE DIMENSION			
HEIGHT			162 MM 6.375 INCHES
WIDTH			143 MM 5.625 INCHES
THICKNESS			2.49 MM 0.098 INCHES
SEPARATOR INSULATION	SEPARATOR THICKNESS		0.065 INCH
	0.020" GLASS MAT		
TERMINALS	FLAG WITH STAINLESS STEEL NUTS AND BOLTS		
COLD CRANK	CCA	0°F / -17.8°C	1721
	MCA	32°F / 0°C	2151
			RESERVE MINUTES AT 25A 830
CAPACITY	20 HR RATE		410
			CAP / AH CURRENT / AMPS
CAPACITY AT THE 20 HOUR RATE		1.265 SP. GR.	410 20.5
CAPACITY AT THE 15 HOUR RATE		1.265 SP. GR.	385 25.7
CAPACITY AT THE 12 HOUR RATE		1.265 SP. GR.	365 30.4
CAPACITY AT THE 10 HOUR RATE		1.265 SP. GR.	349 34.9
CAPACITY AT THE 8 HOUR RATE		1.265 SP. GR.	328 41.0
CAPACITY AT THE 6 HOUR RATE		1.265 SP. GR.	303 50.6
CAPACITY AT THE 5 HOUR RATE		1.265 SP. GR.	287 57
CAPACITY AT THE 4 HOUR RATE		1.265 SP. GR.	267 67
CAPACITY AT THE 3 HOUR RATE		1.265 SP. GR.	242 81
CAPACITY AT THE 2 HOUR RATE		1.265 SP. GR.	209 105
CAPACITY AT THE 1 HOUR RATE		1.265 SP. GR.	148 148



PART NUMBER:	6-EHG-31P
WEIGHT WET:	133 LB / 60 KG
WEIGHT DRY:	104 LB / 47 KG
CAPACITY:	410 AH 20 HR
CCA @ 0°F / -17.8 °C:	1,891 A
CCA @ 32°F / 0 °C:	2,364 A
VOLTAGE:	6 V
OVERALL DIMENSIONS:	20 3/4x 8x 12 3/4"
 MAX HEIGHT WITH OPTIONAL HYDROCAPS:	13.3" / 338 MM

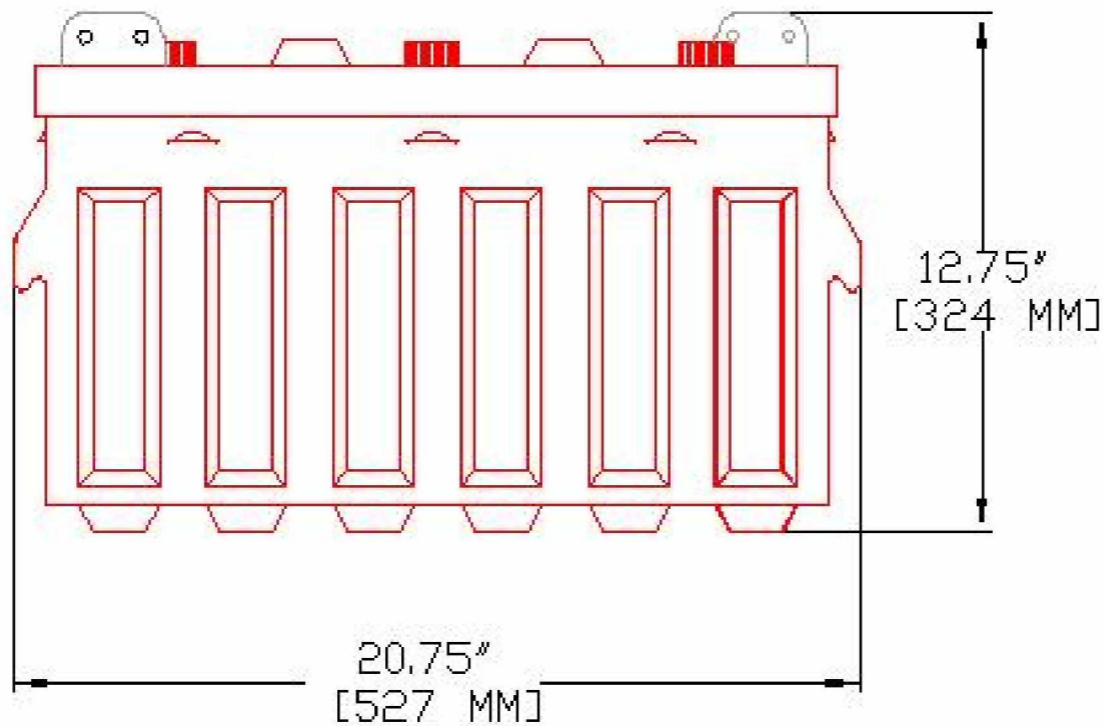
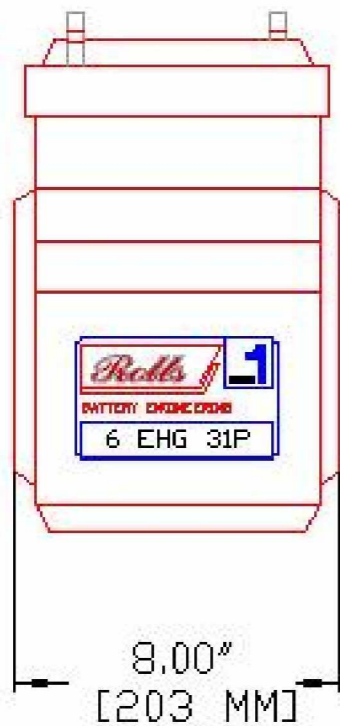

Rolls

BATTERY ENGINEERING SALEM, MASS

TITLE:
6EHG31P

DESCRIPTION:
6V DEEP CYCLE 400/4000 SERIES

CONTACT INFO:
WEB: WWW.ROLLSBATTERY.COM
E-MAIL: SALES@ROLLSBATTERY.COM
PHONE: 1-800-681-9914

SCALE: 1" = 6" 1" = 4" JPEG
0.5" X 11" 11" X 17" NOT TO SCALE

Drawn by: S. WILES Approved By: D. SURRETTE

DATE: 20-Feb-01 REVISION 1.1

DRAWING NO.: DWG 004, BD6EHG31P